



Herkules ERL

- heavy duty profile for vibration-free driving on joint areas for transitions between floor slabs with different thicknesses
- ultra-stable profile head with sinusoidal joint
- decoupling of sound and vibrations
- extremely high load bearing capacity
- suited for all kinds of industrial vehicles

Description / Details:

Heavy duty profile Herkules ERL, base material S355JR. Joint system for vibration-free driving on joint areas for transitions between floor slabs with different thicknesses. Stand-alone joint system with two stands per elements. Large L-form stands. Extension via intergrated threaded joint. Variable element lengths. Accurate to size end pieces from 1000 mm - 2500 mm as well as angle, cross and T-shaped parts available.

Profile / Item no.	Profile height	Profile head	Element length
Herkules ERL	100 mm - 400 mm	base material S355JR primed	2500 mm
Herkules ERLV	100 mm - 400 mm	base material S355JR electro galvanized	2500 mm
Herkules ERL2A	100 mm - 400 mm	stainless steel material 1.431	2500 mm

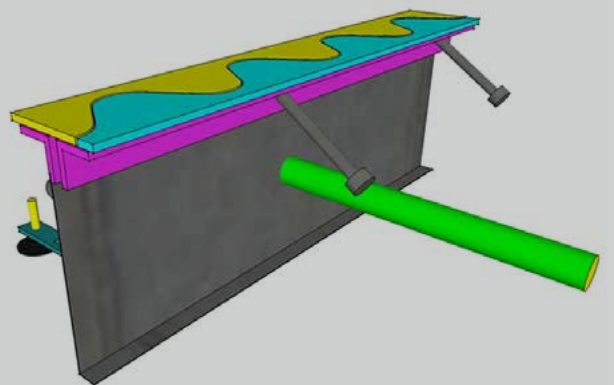
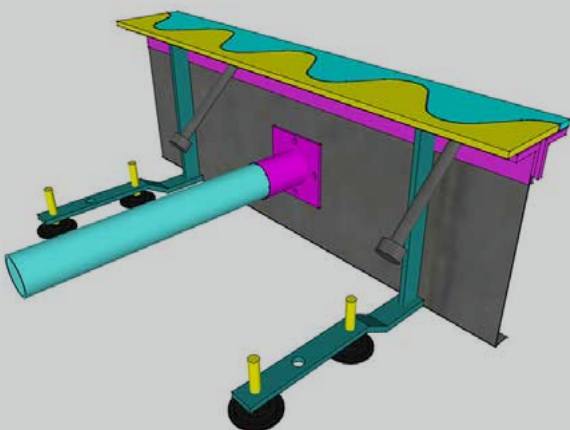
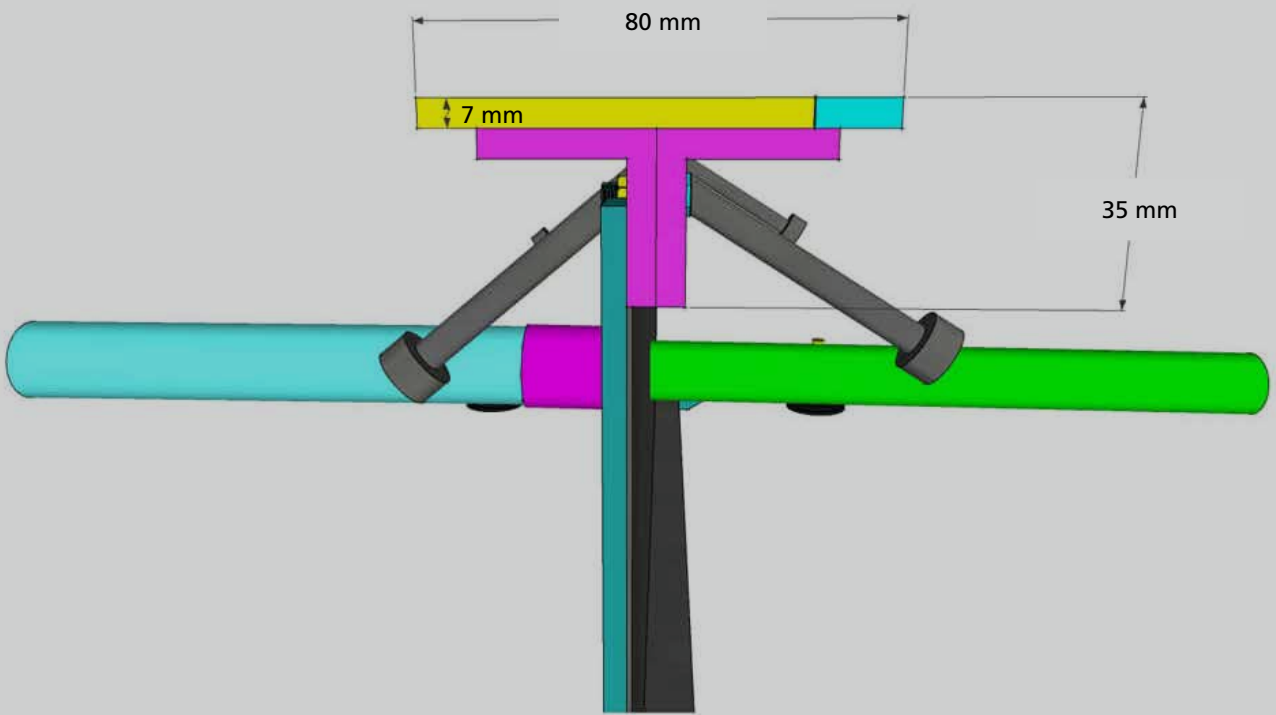

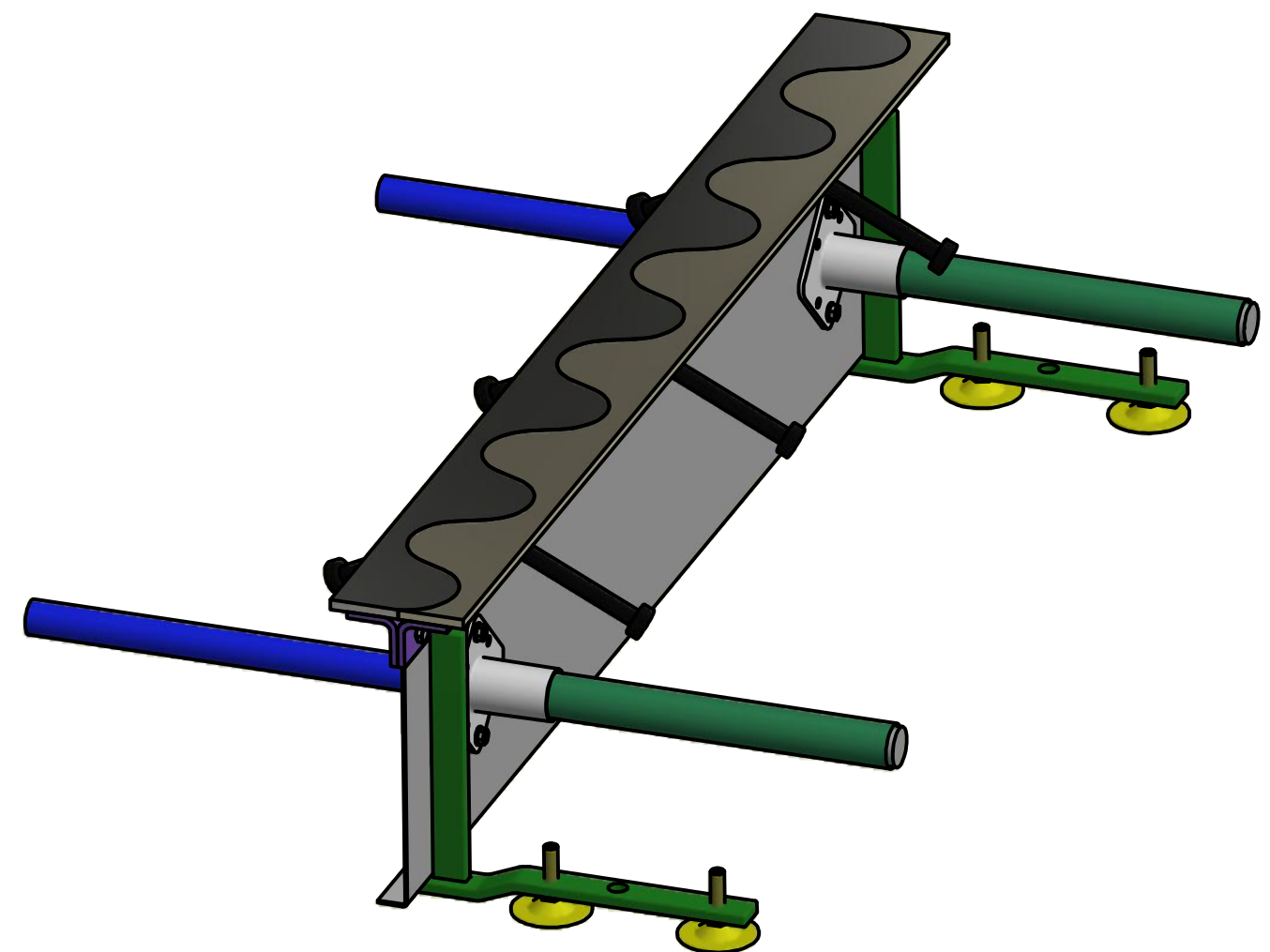
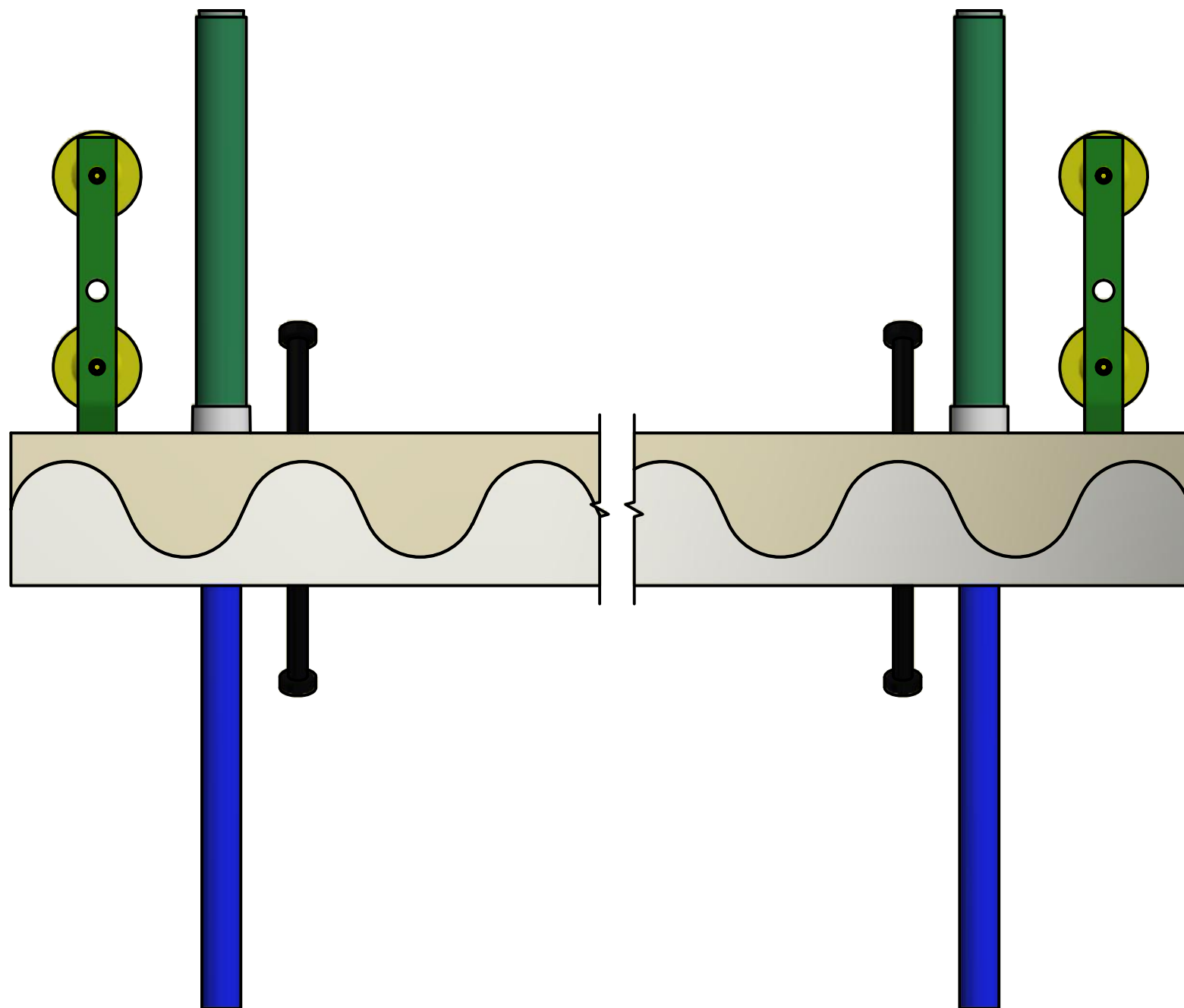
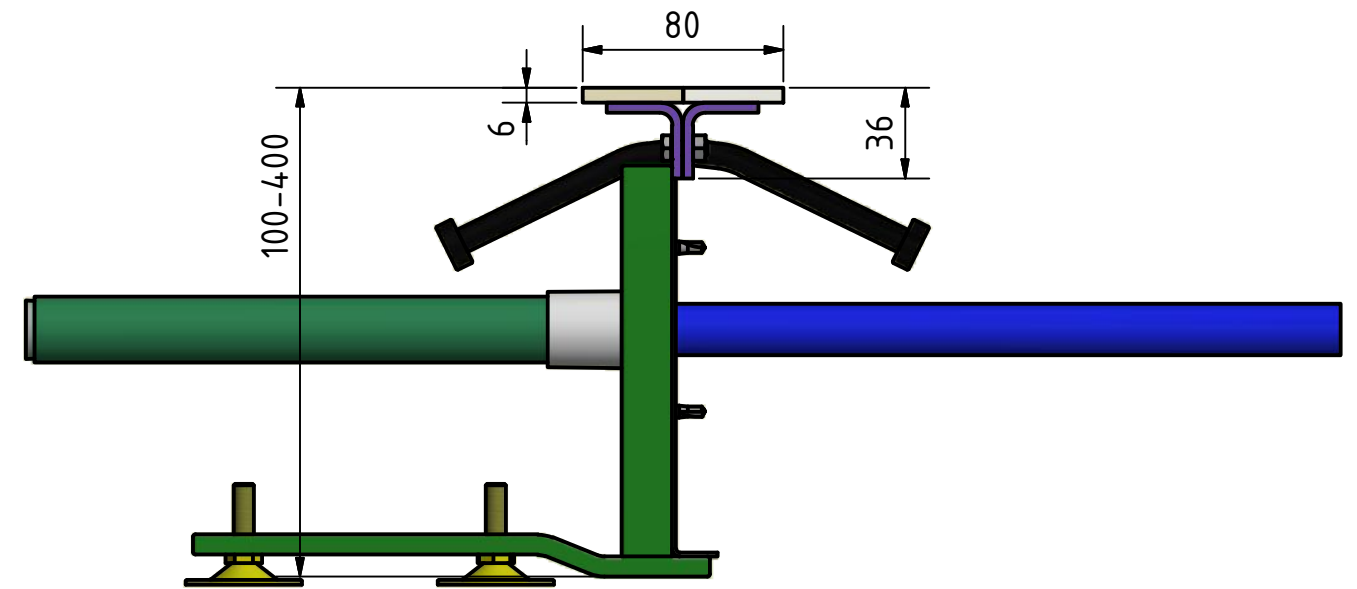
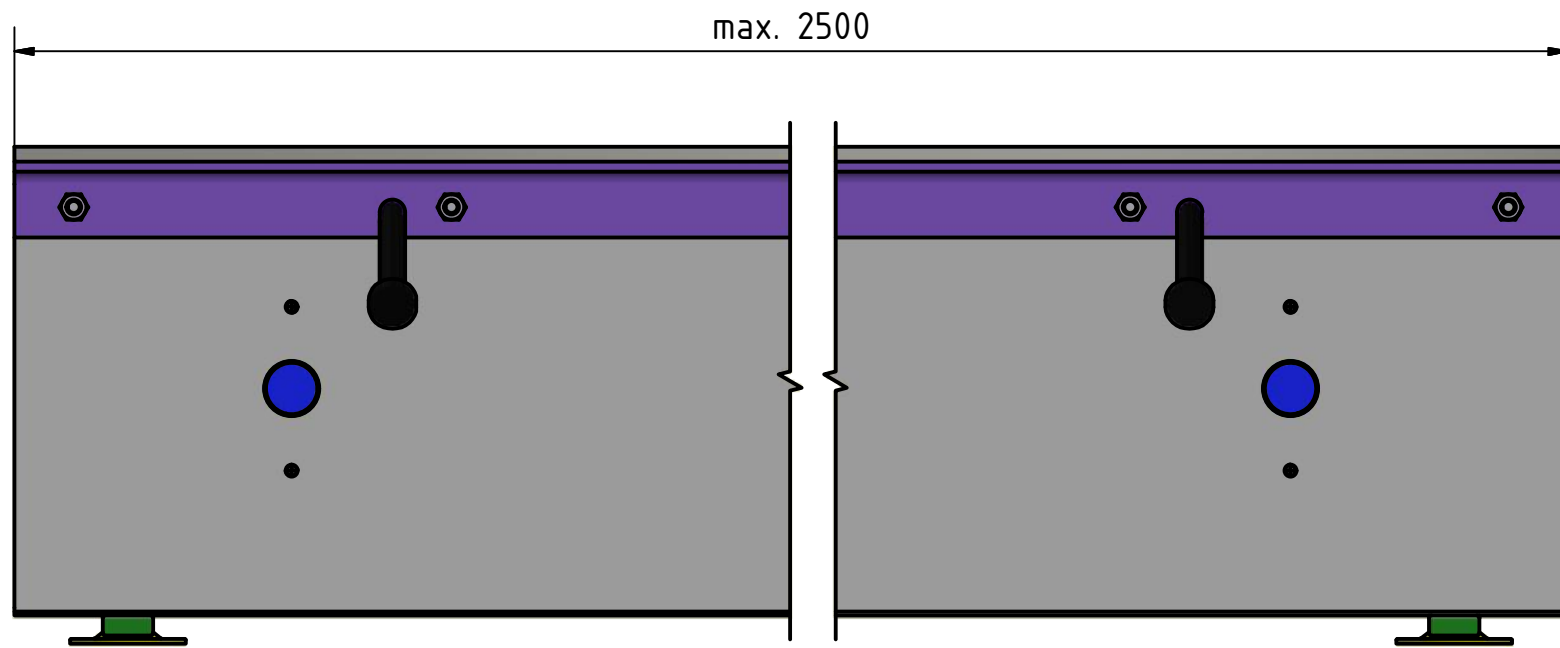

Herkules ERL



guggemos gmbh
www.fugenprofile.de

Iglauer Straße 6, 86316 Friedberg-Derching
Telefon: +49 (821) 4559690, Fax: +49 (821) 4559696
eMail: service@fugenprofile.de