



## Herkules ER

- heavy joint profile for vibration-free driving on joint areas in industrial concrete floor slabs
- ultra-stable profile head with sinusoidal joint
- extremely high load bearing capacity
- suited for all kinds of floor conveyors
- serves as expansion joint, formwork, stop end and reference point for final floor height

### Description / Details:

Heavy duty profile HERKULES ER, base material S355JR. Joint system for vibration-free driving on expansion joints, formwork and stop ends. Stand-alone joint system with two stands per element. Height adjustment via threaded foot. Extension via integrated threaded joint. Variable element lengths. Accurate to size end pieces from 1000 mm - 2500 mm as well as angle, cross and T-shaped parts available.

Profile / Item no.	Profile height	Profile head	Element length
Herkules ER	100 mm - 400 mm	base material S355JR primed	2500 mm
Herkules ERV	100 mm - 400 mm	base material S355JR electro galvanized	2500 mm
Herkules ER2A	100 mm - 400 mm	stainless steel material 1.431	2500 mm

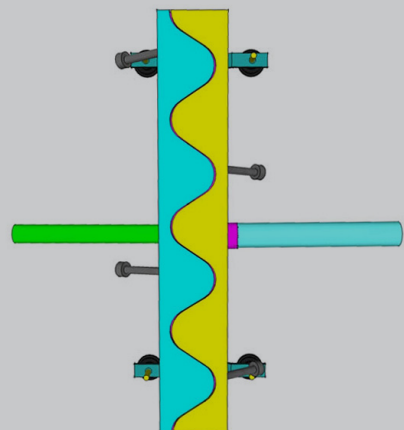
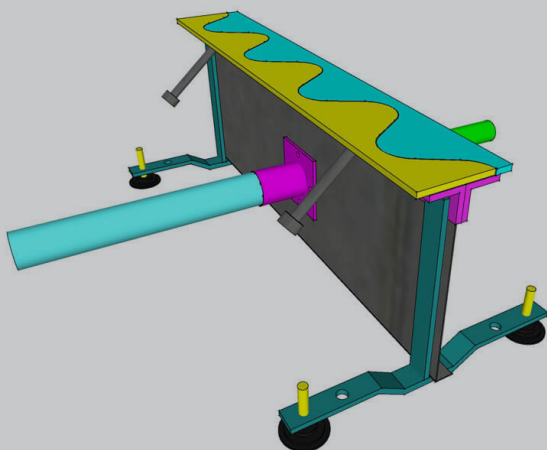
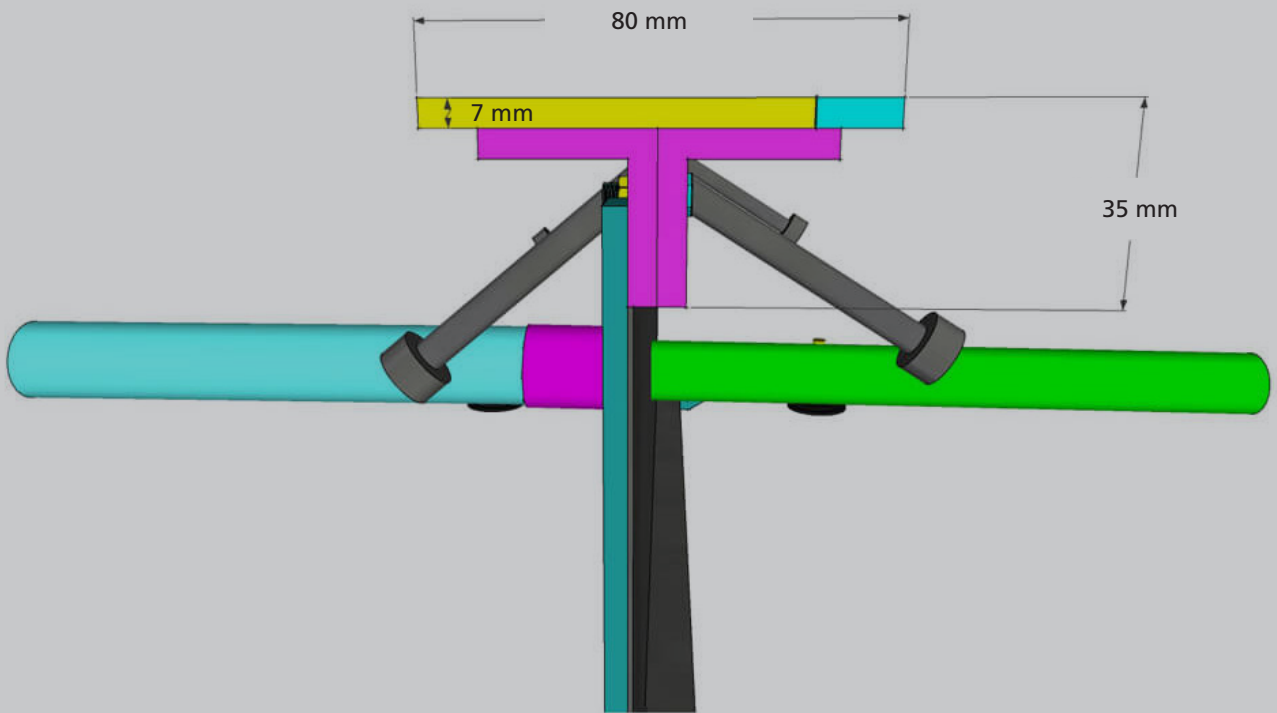

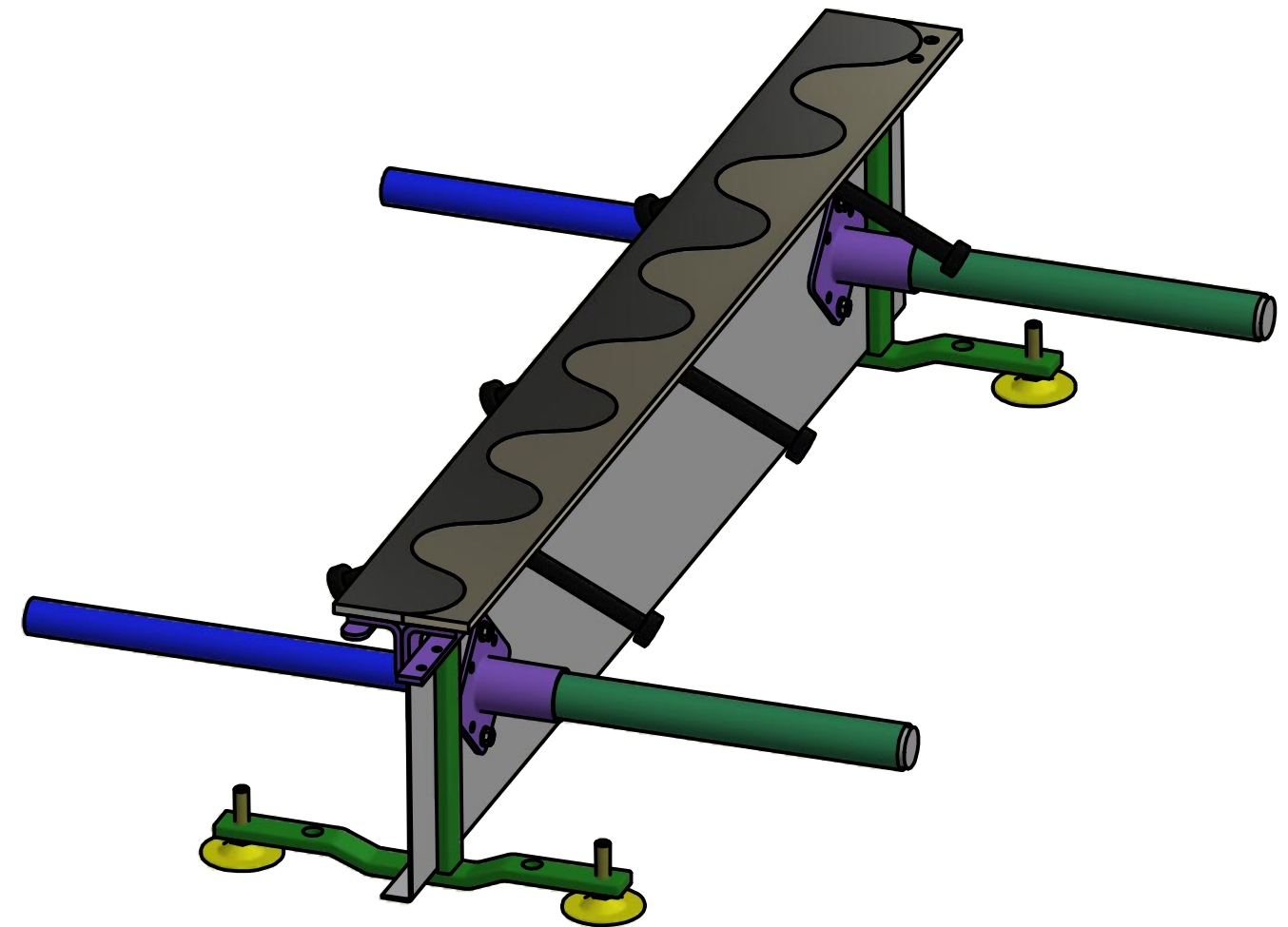
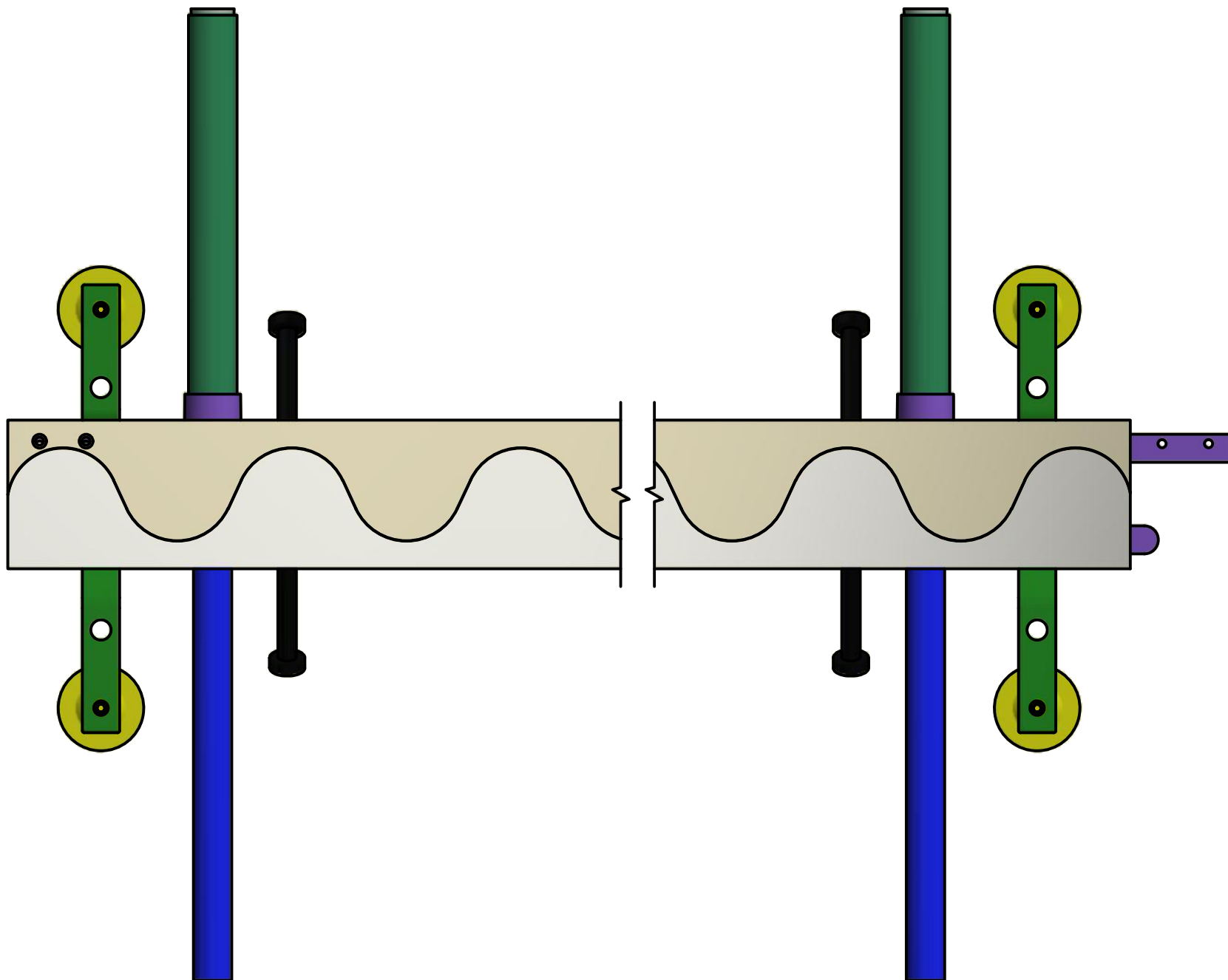
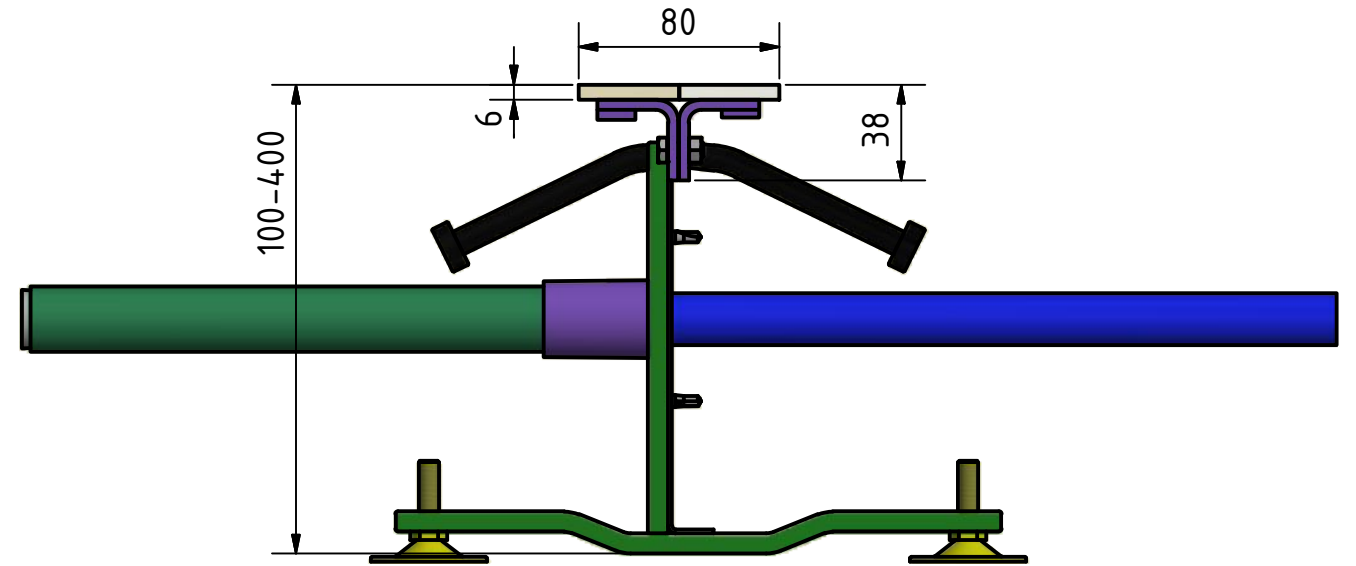
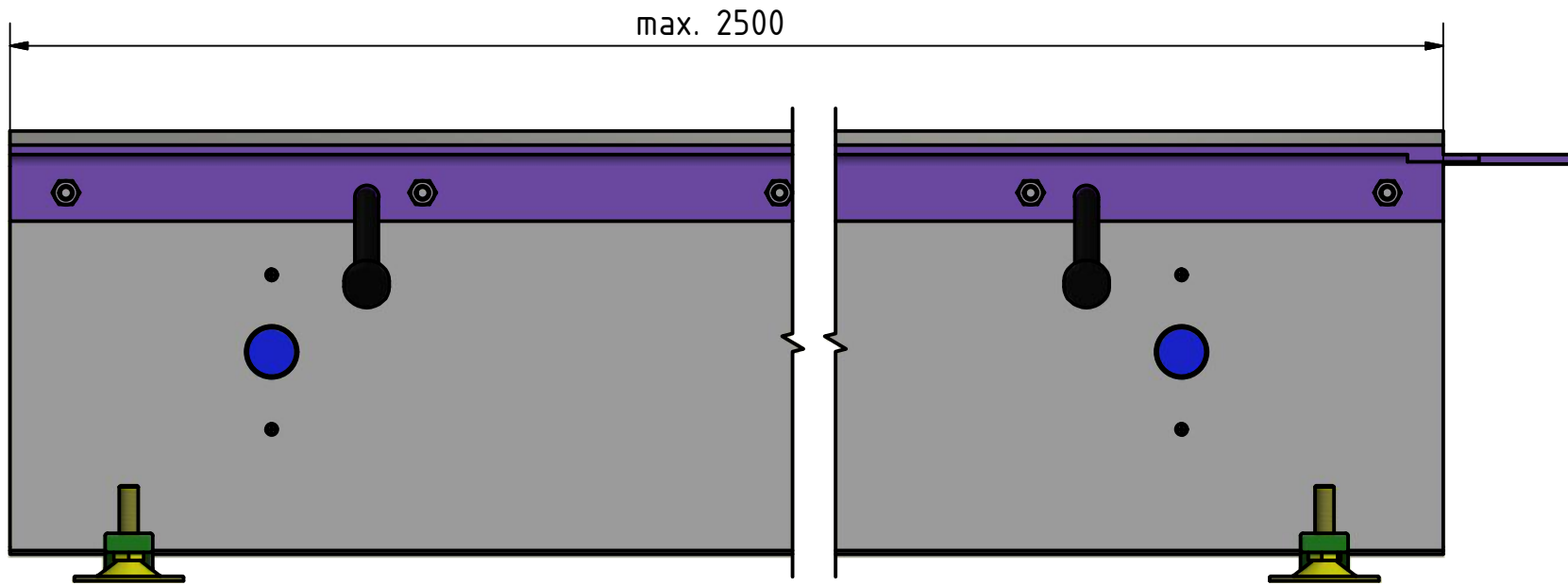

Herkules ER



Iglauer Straße 6, 86316 Friedberg-Derching  
Telefon: +49 (821) 4559690, Fax: +49 (821) 4559696  
eMail: service@fugenprofile.de