

Installation construction for Herkules RFL

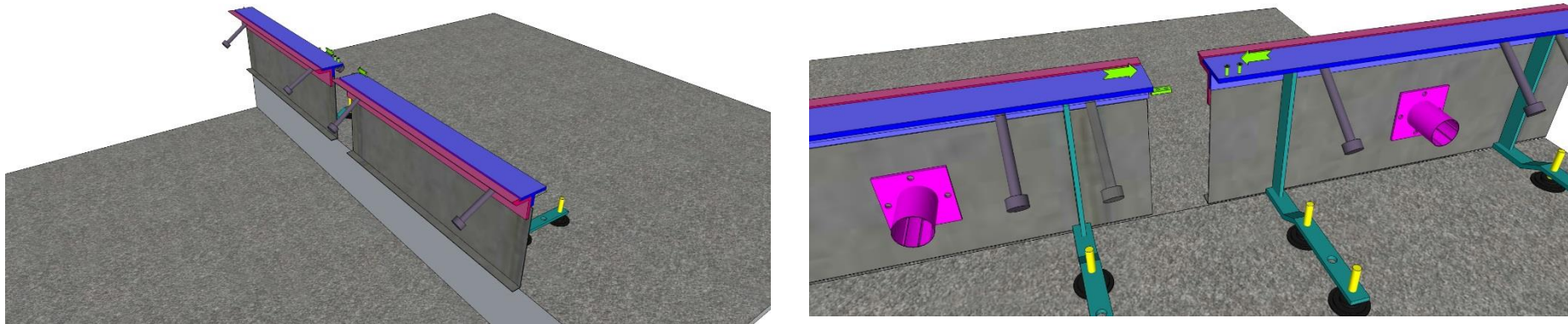

1. Positioning and extending elements

Place the individual elements loosely together along the entire length of the appropriate axis.

Now connect and extend the individual profiles with using the integrated screw connections on the beginning and end of each element and determine the dimensions for the end pieces.

If you have not ordered the profiles in the appropriate dimensions you can use conventional standard elements that cut the sections exactly to the wished size with a diamond blade. These end pieces and intersections can also be connected with the integrated screw connections.

If the end pieces have only one profile stand foot, make sure that they are adequately fixed (please see point 3).



GUGGEMOS GmbH & Co. KG

FUGENPROFILE.DE

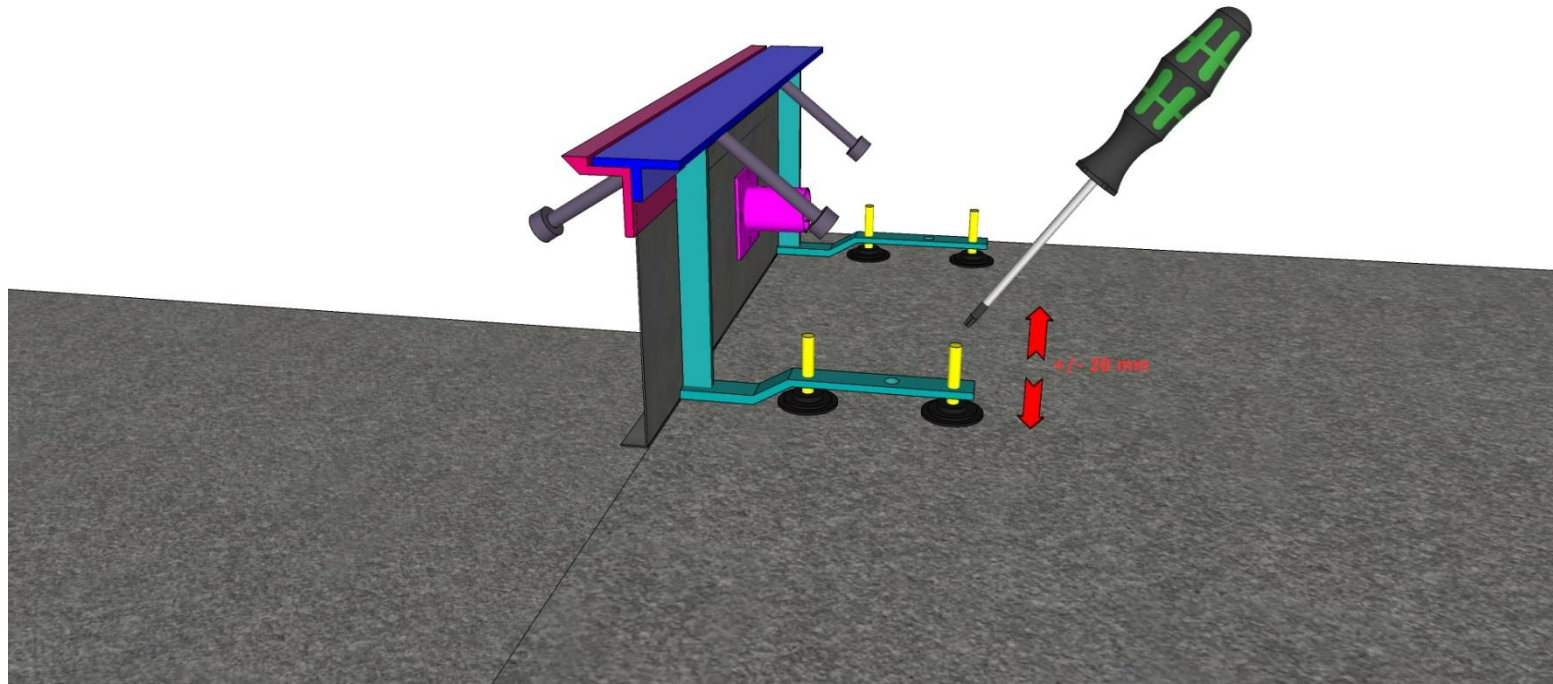

2. Height adjustment

The height adjustment is made by the integrated set screws in the profile foot. You can adjust the joint profiles by a maximum of 20 mm (+) in height.

The profile head is also a height reference point for the top edge of the already finished component.

Be sure to create a flow barrier at the bottom of the profile sheet to ensure complete separation of the components.

We recommend a PE-edge insulation strip and/or PU-construction foam.

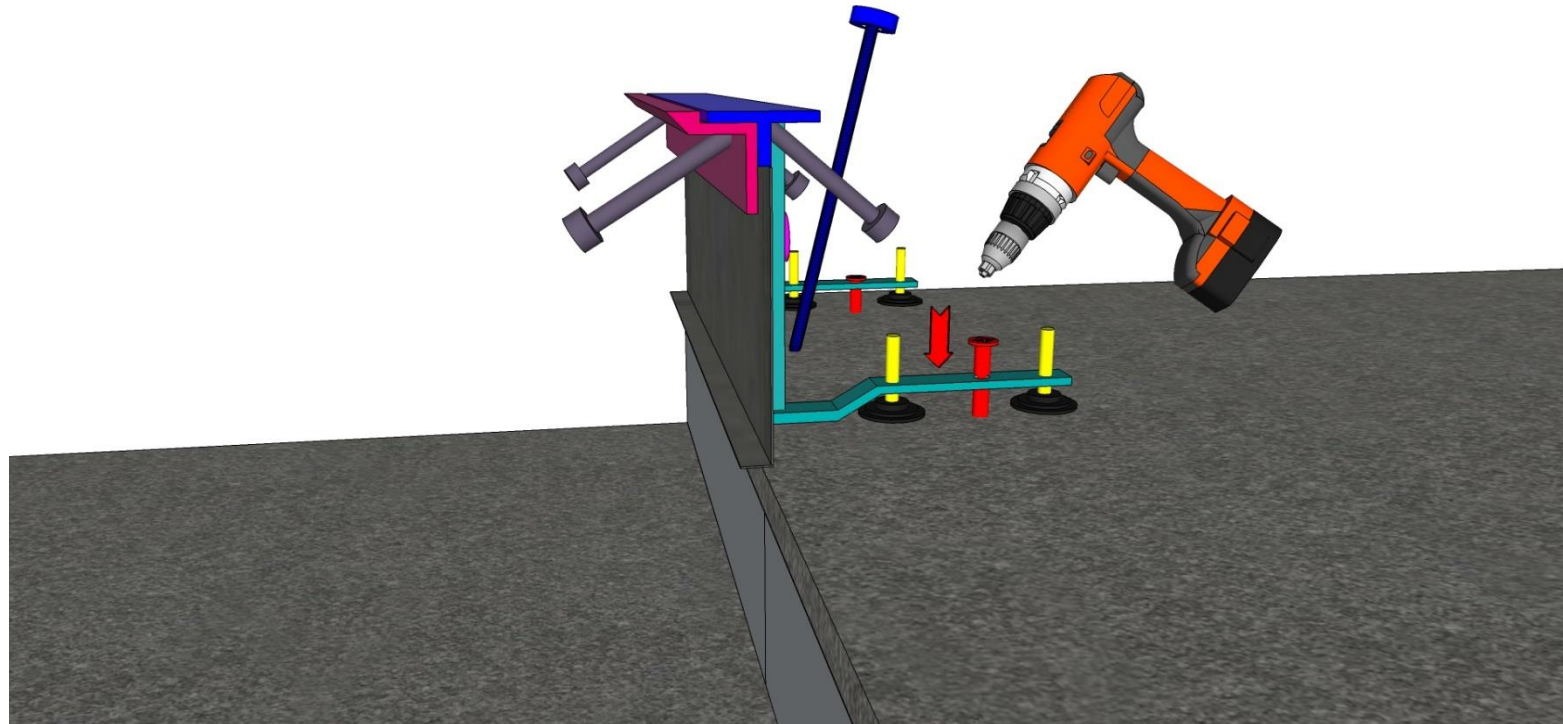

3. Fixation on the ground

In the profile stand foot mounting holes are integrated with 8 mm diameter. The profile can be bolted to the ground (e.g. on a clean layer) there. Fixing with steel pins (on gravel surfaces) which are knocked into the ground can be done alternatively or in combination. The steel pins can be connected to weld points on the tread anchors.

The fixation of the profiles can be done in several ways. This usually depends on the local conditions. However, the above mentioned variants have the best experience.

Please make sure by taking any measures that the joint profile for the concrete floor is adequately fixed and stabilized but not rigidly connected to the ground. Rigid connections impair the natural absorption of movement when the concrete surfaces shrink.

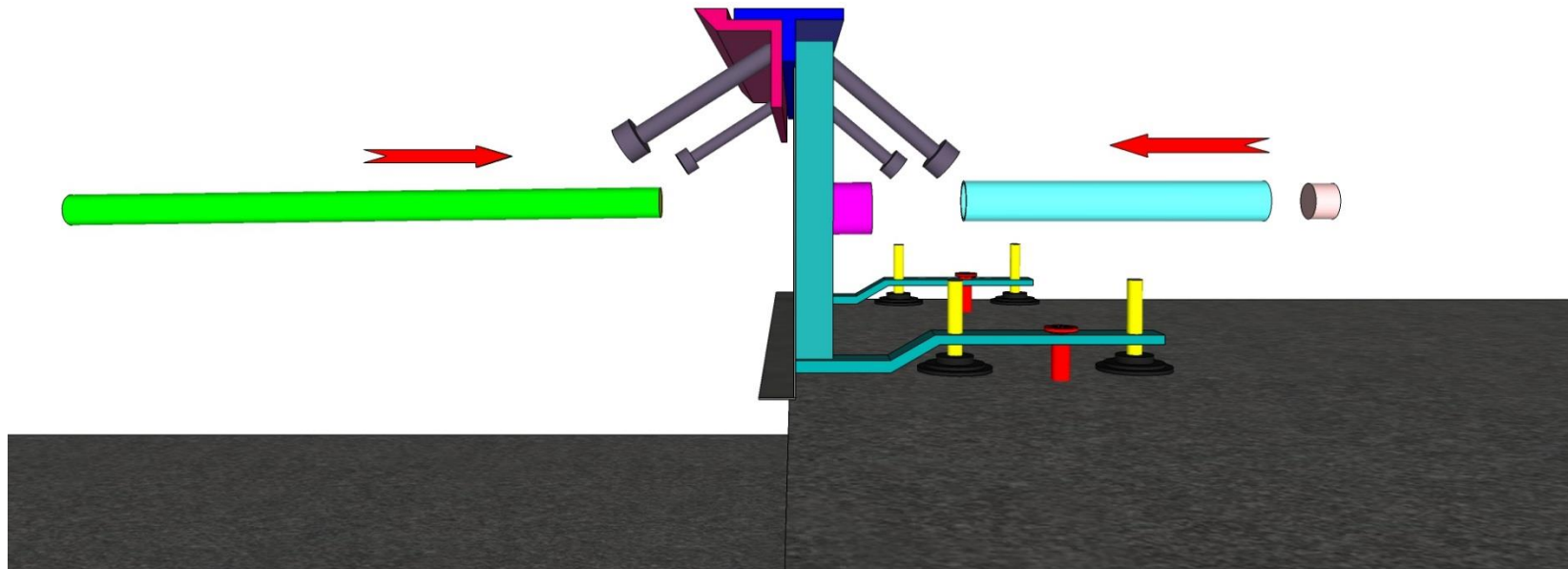

4. Load transfer dowel and dowel sleeves

The profiles provide an integrated sleeve system for securing the height of the load transfer dowel. In the first step attach the sleeve system to the profile sheet and then from the other side the load transfer dowel. Please consult the responsible planner/structural engineer specifying the object and the local conditions for a correct choice of the dimension and position of the load transfer dowels.

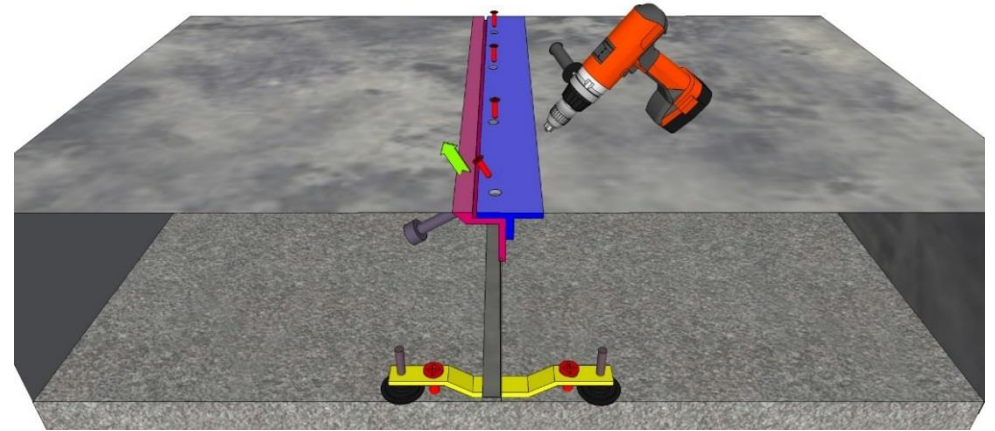
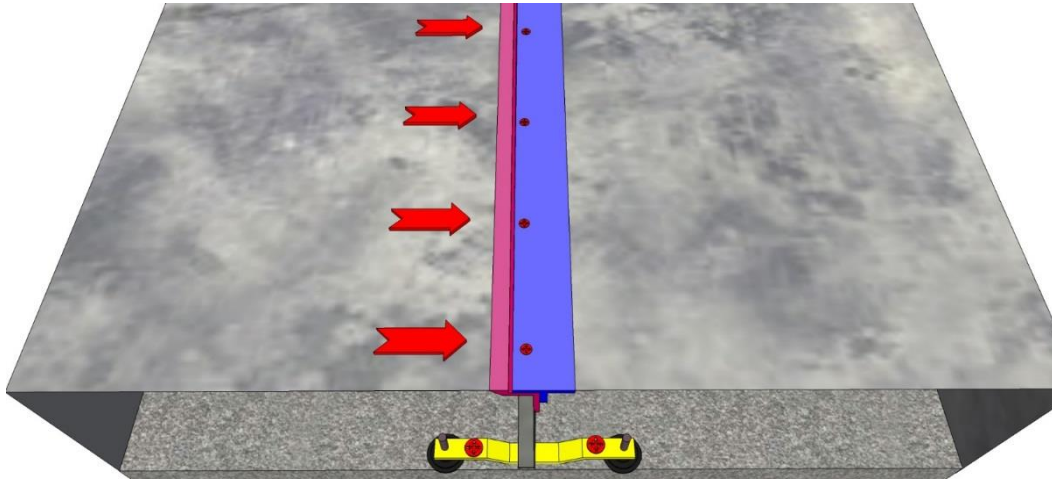

5. Protect the profile head

Please use a fibre-reinforced and residue-free tape to mask the profile head for protecting against dirt due to the following measure.

6. Loosening up the transport lock

Please loosen up the coloured transport safety bolt in the profile head to guarantee a free movement capability.

In rare cases there could be some tensions in the profile head due to overtightened fixation with the screw anchors from the previous step. Those are now seen as sharp-edged unevennesses in the profile head after loosening up the transport lock.

Loosen up the overtightened screw anchors in this area until slight unevennesses are going back. For bigger unevennesses please renew all screw anchors.

The transport safety bolts will not be fastened in again to the profile head.

The profile system is now ready to start concreting.

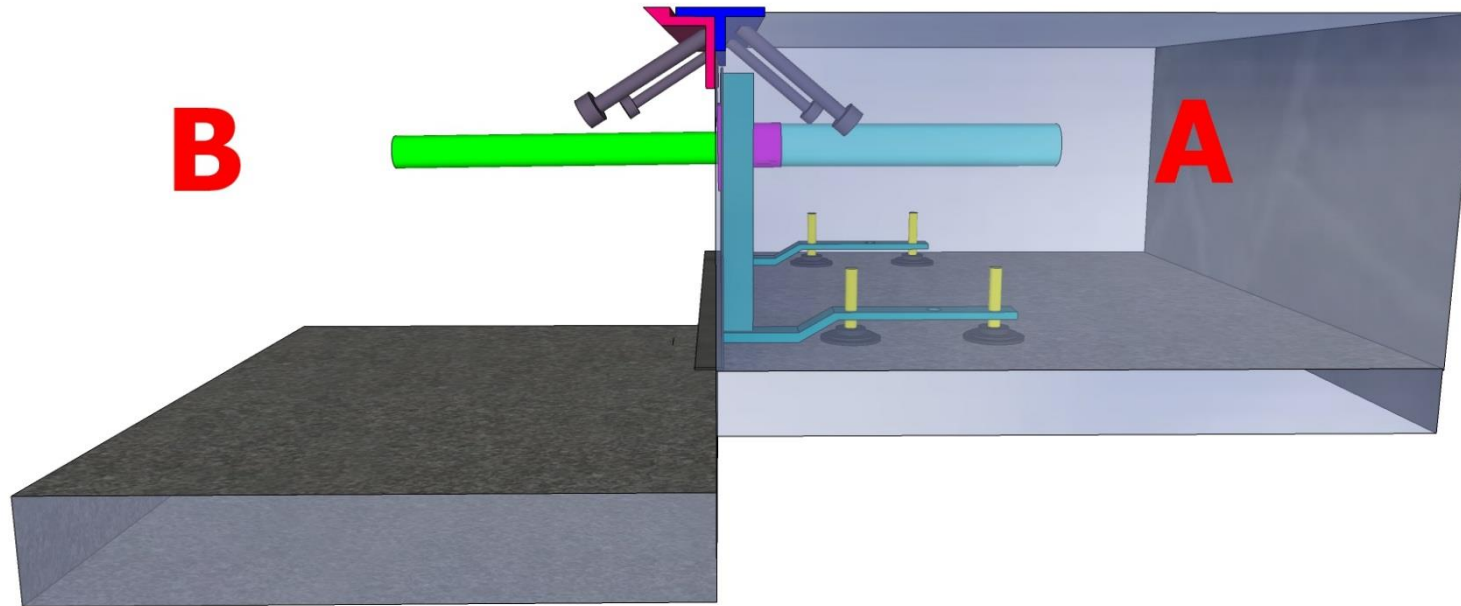

7. Loosening up the transport lock with simultaneous assembly (A&B)

Loosening up the transport lock in case of staggered concreting (e.g. A and after 24h B):

Start with concreting on the profile side A and do not release the transport locks at any time. Only after temporary installation on the profile side B please loosen up the transport lock as follows:

As soon as the setting of the concrete surfaces has progressed to such an extent that they can be walked on or before the first shrinkage movement begins, the transport safety devices must be removed!

Please make sure you take care of a smooth movement of the profile.



GUGGEMOS GmbH & Co. KG

FUGENPROFILE.DE

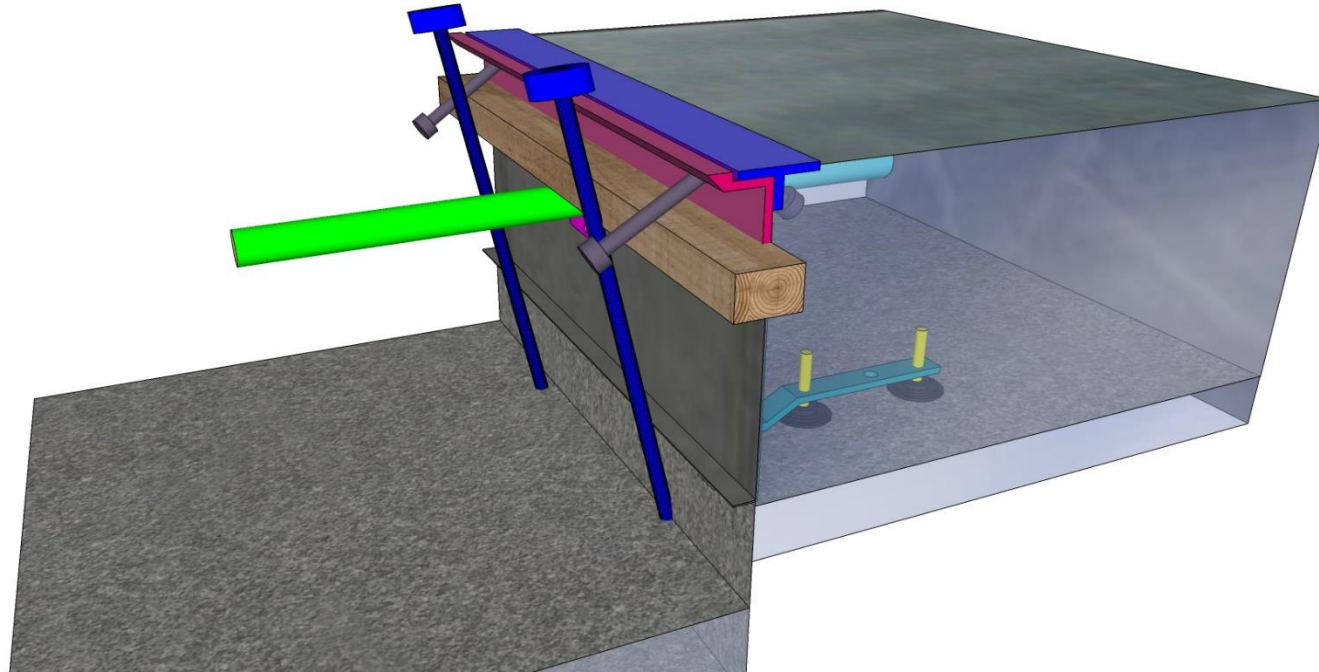

Additional information:

8. Additional fixation

For floor slab thicknesses greater than 20 cm and / or soft substrates, it is advisable to fix the joint profiles with additional measures against the concrete pressure.

For your information: Our application-related recommendations comply with our experiences. We recommend to match the installation with the local conditions and refer to our general terms and conditions as well as of sale and delivery. As a basic principle, we reject any liability claims for above mentioned indications